

2009-09-28

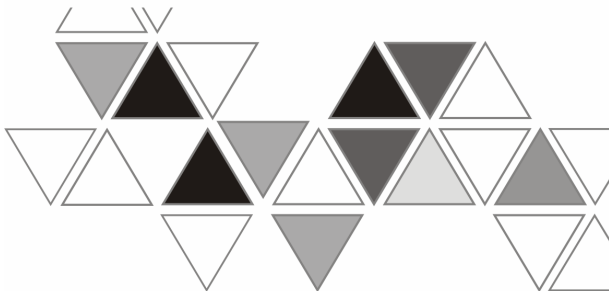

5011671202-PT42



DVP04PT-S

INSTRUCTION SHEET

安裝說明

安装说明

BILGI DÖKÜMANI

- ▲ *Temperature Measurement Module*
- ▲ 溫度量測模組
- ▲ 温度测量模块
- ▲ *Sıcaklık Ölçüm Modülü*



<http://www.delta.com.tw/industrialautomation>

Thank you for choosing Delta DVP series PLC. DVP04PT-S is able to receive 4 points of platinum temperature sensors and convert them into 14-bit digital signals. Besides, through FROM/TO instructions in DVP Slim series MPU program, the data in DVP04PT-S can be read and written. There are many 16-bit control registers (CR) in DVP04PT-S. The power unit is separate from it and is small in size and easy to install.

- ✦ Please read this instruction sheet carefully before use.
- ✦ This is an OPEN TYPE I/O module and therefore should be installed in an enclosure free of airborne dust, humidity, electric shock and vibration. The enclosure should prevent non-maintenance staff from operating the device (e.g. key or specific tools are required for operating the enclosure) in case danger and damage on the device may occur.
- ✦ DO NOT apply AC power to any of the input/output terminals, or it may damage DVP04PT-S.
- ✦ DO NOT touch any terminal when the power is switched on.
- ✦ Make sure that the DVP04PT-S is properly grounded ⚡, to prevent any electromagnetic noise.
- ✦ Please keep the wires as short as possible when connecting RTD to PLC and keep power lead as far away as possible from I/O wires to prevent noise interference.

■ Product Profile & Dimension

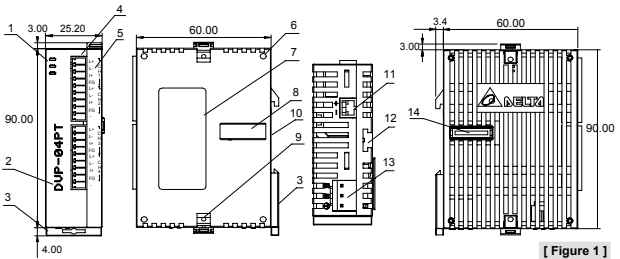

[Figure 1]

Unit: mm

1. Status indicator (POWER, RUN and ERROR)	8. I/O module connection port
2. Model name	9. I/O module clip
3. DIN rail clip	10. DIN rail (35mm)
4. I/O terminals	11. RS-485 communication port
5. I/O point indicator	12. I/O module clip
6. Mounting holes	13. DC power input
7. Specification label	14. I/O module connection port

■ I/O Terminal Layout



External Wiring

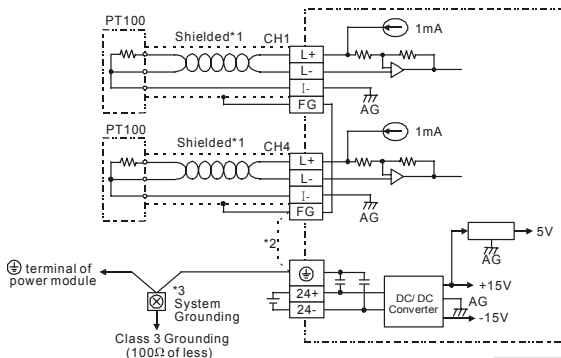

[Figure 2]

Note1: Use only the wires that are packed with the temperature sensor (PT100) for analog input and separate from other power line or any wire that may cause noise. Please use 3-wire for PT100.

Note2: Terminal FG is grounded for noise suppression.

Note3: Please connect ⊕ power supply module terminal and ⊕ DVP04PT-S temperature measurement module terminal to system earth ground.

Warning: DO NOT connect wires to the No Connection terminals.

Electrical Specifications

Power supply voltage	24VDC (20.4VDC ~ 28.8VDC) (-15% ~ +20%)
Max. rated power consumption	2W, supplied by external power.
Operation/storage	Operation: 0°C~55°C (temp.), 50~95% (humidity), pollution degree 2 Storage: -25°C~70°C (temp.), 5~95% (humidity)
Vibration/shock resistance	International standards: IEC61131-2, IEC 68-2-6 (TEST Fc)/ IEC61131-2 & IEC 68-2-27 (TEST Ea)
Series connection to DVP-PLC MPU	The modules are numbered from 0 to 7 automatically by their distance from MPU. No.0 is the closest to MPU and No.7 is the furthest. Maximum 8 modules are allowed to connect to MPU and will not occupy any digital I/O points.

Functional Specifications

DVP04PT-S	Celsius (°C)	Fahrenheit (°F)
Analog input channel	4 channels per module	
Sensors type	3- WIRE PT 100Ω 3850 PPM/°C (DIN 43760 JIS C1604-1989)	
Current excitation	1mA	
Temperature input range	-200°C ~ 600°C	-328°F ~ 1112°F
Digital conversion range	K-2,000 ~ K6,000	K-3,280 ~ K11,120
Resolution	14 bits (0.1°C)	14 bits (0.1°F)
Overall accuracy	±0.5% of full scale of 25°C (77°F), ±1% of full scale during 0 ~ 55°C (32 ~ 131°F).	
Response time	200ms × channels	

DVP04PT-S	Celsius (°C)	Fahrenheit (°F)
Isolation method	Isolation between digital and analog circuitry. There is no isolation between channels. 500VDC between digital circuits and Ground 500VDC between analog circuits and Ground 500VDC between analog circuits and digital circuits 500VDC between 24VDC and Ground	
Digital data format	2's complement of 16-bit	
Average function	Yes (CR#2 ~ CR#5)	
Self diagnostic function	Yes	
Communication mode (RS-485)	Yes (CR#32). RS-485 is disabled when the DVP04PT-S is connected in series with an MPU.	

■ Control Register

CR#	Address	Save		Register content	Description
#0	H'4064	O	R	Model name	Set up by the system: DVP04PT model code = H'8A.
#2	H'4066	O	R/W	CH1 average number	Number piece of readings used for the calculation of "average" temperature on channels CH1 ~ CH4. Setting range: For versions prior to V3.04: K1 ~ K4,095. For versions after V3.05: K1 ~ K20. Default setting is K10.
#3	H'4067	O	R/W	CH2 average number	
#4	H'4068	O	R/W	CH3 average number	
#5	H'4069	O	R/W	CH4 average number	
#6	H'406A	X	R	CH1 average degrees	
#7	H'406B	X	R	CH2 average degrees	Average degrees for channels CH1 ~ CH4. (Unit: 0.1°C).
#8	H'406C	X	R	CH3 average degrees	
#9	H'406D	X	R	CH4 average degrees	
#12	H'4070	X	R	CH1 average degrees	
#13	H'4071	X	R	CH2 average degrees	Average degrees for channels CH1 ~ CH4. (Unit: 0.1°F).
#14	H'4072	X	R	CH3 average degrees	
#15	H'4073	X	R	CH4 average degrees	
#18	H'4076	X	R	Present temp. of CH1	
#19	H'4077	X	R	Present temp. of CH2	Present temperature of channels CH1 ~ CH4. (Unit: 0.1°C).
#20	H'4078	X	R	Present temp. of CH3	
#21	H'4079	X	R	Present temp. of CH4	
#24	H'407C	X	R	Present temp. of CH1	
#25	H'407D	X	R	Present temp. of CH2	Present temperature of channels CH1 ~ CH4. (Unit: 0.1°F).
#26	H'407E	X	R	Present temp. of CH3	
#27	H'407F	X	R	Present temp. of CH4	
#29	H'4081	X	R/W	PID mode setting	
#30	H'4082	X	R	Error status	Data register stores the error status. Refer to the error code chart for details.
#31	H'4083	O	R/W	Communication address setting	RS-485 communication address. Setting range is 01 ~ 254 and default setting is K1.
#32	H'4084	O	R/W	Communication baud rate setting	Communication baud rate. For ASCII mode, date format is 7 bits, even, 1 stop bit (7, E, 1), while RTU mode, date format is 8 bits, even, 1 stop bit (8, E, 1). b0: 4,800 bps (bit/sec). b1: 9,600 bps (bit/sec). (default setting)

CR#	Address	Save	Register content	Description
#32	H'4084	O	R/W	Communication baud rate setting b2: 19,200 bps (bit/sec). b3: 38,400 bps (bit/sec). b4: 57600 bps (bit/sec). b5: 115,200 bps (bit/sec). b6 ~ b13: Reserved. b14: switch between low bit and high bit of CRC code (RTU mode only). b15: RTU mode.
#33	H'4085	O	R/W	Reset to default setting b15~b12 b11~b9 b8~b6 b5~b3 b2~b0 ERR LED CH4 CH3 CH2 CH1 Example: Setting of CH1 1. b0 ~ b1: Reserved. 2. b2: Set to 1 and PLC will be reset to default settings. Definition of ERR LED: b12~b15=1111 (default settings) 1. b12 corresponds to CH1: when b12=1, scale exceeds the range, ERR LED flashes. 2. b13 corresponds to CH2: when b13=1, scale exceeds the range, ERR LED flashes. 3. b14 corresponds to CH3: when b14=1, scale exceeds the range, ERR LED flashes. 4. b15 corresponds to CH4: when b15=1, scale exceeds the range, ERR LED flashes.
#34	H'4086	O	R	Software version Display the software version in hexadecimal. ex: H'010A = version 1.0A
#35 ~ #48			System used	
Symbols: O: means latched. X: means not latched. (Support when using RS-485 communication, not support when connecting with MPU) R: able to read data by using FROM instruction or RS-485. W: able to write data by using TO instruction or RS-485.				

- Function code: 03'H - read data from register. 06'H - write one word to register. 10'H - write multiple words to registers.
- CR#30 is the error code register. Refer to the chart below:

Error description	Content	b15 ~ b8	b7	b6	b5	b4	b3	b2	b1	b0
Power source abnormal	K1 (H'1)	Reserved	0	0	0	0	0	0	0	1
Wiring to empty external contact	K2 (H'2)		0	0	0	0	0	0	1	0
Hardware malfunction	K16 (H'10)		0	0	0	1	0	0	0	0
Average times setting error	K64 (H'40)		0	1	0	0	0	0	0	0
Instruction error	K128 (H'80)		1	0	0	0	0	0	0	0
Note: Each error code will have corresponding bit (b0 ~ b7). Two or more errors may happen at the same time. 0 means normal and 1 means having error.										

- When CR#29 is set to H'5678, CR#0 ~ CR#34 can be used for PID settings in DVP04PT-S V3.08 and versions above.

PID Mode Content Description			
CR#0	Model name	CR#4	Output % at CH3
CR#2	Output % at CH1	CR#5	Output % at CH4
CR#3	Output % at CH2	CR#6	CH1 average degrees (°C)

PID Mode Content Description			
CR#7	CH2 average degrees (°C)	CR#21	CH3 K _i
CR#8	CH3 average degrees (°C)	CR#22	CH4 K _i
CR#9	CH4 average degrees (°C)	CR#24	CH1 K _D
CR#10	Set temperature at CH1	CR#25	CH2 K _D
CR#11	Set temperature at CH2	CR#26	CH3 K _D
CR#12	Set temperature at CH3	CR#27	CH4 K _D
CR#13	Set temperature at CH4	CR#28	Run/Stop & Auto turning
CR#14	CH1 K _p	CR#29	Enter PID mode(H'5678)
CR#15	CH2 K _p	CR#30	Error Code
CR#16	CH3 K _p	CR#31	CH1 Sampling time
CR#17	CH4 K _p	CR#32	CH2 Sampling time
CR#19	CH1 K _i	CR#33	CH3 Sampling time
CR#20	CH2 K _i	CR#34	CH4 Sampling time

感謝您採用台達 DVP 系列產品。DVP04PT-S 溫度量測模組可接受外部 4 點鉑金屬溫度感測器，將之轉換成 14 位元之數位信號。透過 DVP-PLC SS/ SA/SX/SC/SV 主機程式以指令 FROM/TO 來讀寫模組內之資料，模組內具有多個 CR (Control Register) 暫存器，每個暫存器有 16 bits。電源單元與模組分離，體積小，安裝容易。

- ✓ 請在使用之前，詳細閱讀本使用說明書。實施配線，務必關閉電源。上電時請勿接觸機體端子或進行維修。輸入電源切斷後，一分鐘之內，請勿觸摸內部電路。
- ✓ 本機為開放型 (OPEN TYPE) 機殼，因此使用者使用本機時，必須將之安裝於具防塵、防潮及免於電擊 / 衝擊意外之外殼配線箱內。另必須具備保護措施（如：特殊之工具或鑰匙才可打開）防止非維護人員操作或意外衝擊本體，造成危險及損壞。
- ✓ 交流輸入電源不可連接於輸入 / 出信號端，否則可能造成嚴重的損壞，因此請在上電之前再次確認電源配線。
- ✓ 本體上之接地端子 \oplus 務必正確的接地，可提高產品抗雜訊能力。
- ✓ 由測溫體到溫調本體的配線路請用最短距離配線，為了避免雜訊及誘導的影響儘可能將電源線和負載配線分開。

■ 產品外觀尺寸與部位介紹

詳細部位指示圖與外觀尺寸請參閱英文版頁碼1之[Figure1]，單位：mm。

1. 電源、錯誤及運行指示燈	6. I/O 模組定位孔	11. RS-485 通訊口
2. 機種型號	7. 銘牌	12. I/O 模組固定槽
3. DIN 軌固定扣	8. I/O 模組連接口	13. 電源輸入口
4. 端子	9. I/O 模組固定扣	14. I/O 模組連接口
5. 端子配置	10. DIN 軌槽 (35mm)	

■ 輸入 / 輸出端子台配置

請參閱英文版頁碼2之端子台配置示意圖。

■ 外部配線

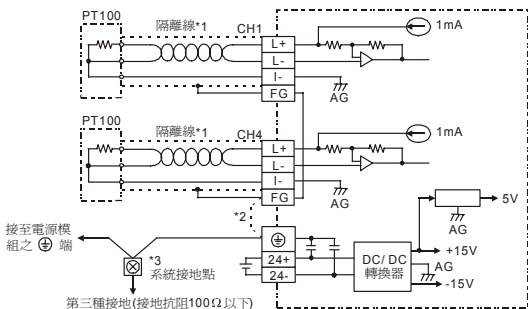

註1：使用於類比輸入的配線應採用PT100溫度感測器之連接線或雙絞隔離線且應與其他電源線或可能引起雜訊之接線分開。PT100請使用3線式溫度感測器。

註2：如果雜訊過大請將FG及接地端子連接。

註3：請將電源模組之 \ominus 端及DVP04PT-S溫度量測模組之 \oplus 端連接到系統接地點，再將系統接地點作第三種接地或接到配電箱之機殼上。

注意：空端子請勿配線。

■ 電氣規格

電源電壓	24VDC (20.4VDC ~ 28.8VDC) (-15% ~ +20%)
額定最大消耗功率	2W, 由外部電源供應
操作 / 儲存環境	1. 操作: 0°C ~ 55°C (溫度), 50 ~ 95% (濕度), 污染等級 2 2. 儲存: -25°C ~ 70°C (溫度), 5 ~ 95% (濕度)
耐振動 / 衝擊	國際標準規範IEC61131-2, IEC 68-2-6 (TEST Fc)/IEC61131-2 & IEC 68-2-27 (TEST Ea)
與DVP-PLC主機串接說明	模組編號以靠近主機之順序自動編號由0到7, 最大可連接8台且不佔用數位I/O點數。

■ 功能規格

DVP04PT-S	攝氏 (°C)	華氏 (°F)
類比訊號輸入通道	4通道 / 台	
適合感應器形式	3線 PT 100Ω 3850 PPM/°C (DIN 43760 JIS C1604-1989)	
驅動電流	1mA	
輸入溫度範圍	-200°C ~ 600°C	-328°F ~ 1112°F
數位轉換範圍	K-2,000 ~ K6,000	K-3,280 ~ K11,120
解析度	14 bits (0.1°C)	14 bits (0.1°F)
總和精密度	±0.5% 在 (25°C, 77°F) 範圍內滿刻度時。 ±1% 在 (0 ~ 55°C, 32 ~ 131°F) 範圍內滿刻度時。	
響應時間	200ms × 通道數	
隔離方式	數位區與類比區有隔離, 通道間未隔離。 數位電路與接地之間: 500VDC 類比電路與接地之間: 500VDC 類比電路與數位電路之間: 500VDC 24VDC與接地之間: 500VDC	
數位資料格式	16位元二補數	
平均功能	有 (CR#2 ~ CR#5)	
自我診斷功能	上下極限值測/通道	
通訊模式 (RS-485)	有(CR#32)。當與PLC主機串接時, RS-485通訊無法使用。	

■ 控制暫存器 (CR)

CR#	參數位址	保持型	暫存器名稱	說明
#0	H'4064	O R	機種型號	系統內定, DVP04PT-S機種編碼= H'8A。
#2	H'4066	O R/W	CH1平均次數	通道CH1 ~ CH4訊號的平均次數設定: V3.04以前版本: 可設定範圍K1 ~ K4,095。 V3.05以後版本: 可設定範圍K1 ~ K20。 出廠設定值為K10。
#3	H'4067	O R/W	CH2平均次數	
#4	H'4068	O R/W	CH3平均次數	
#5	H'4069	O R/W	CH4平均次數	
#6	H'406A	X R	CH1量測攝氏溫度平均值	通道CH1 ~ CH4量測攝氏溫度平均值顯示。單位0.1°C。
#7	H'406B	X R	CH2量測攝氏溫度平均值	
#8	H'406C	X R	CH3量測攝氏溫度平均值	
#9	H'406D	X R	CH4量測攝氏溫度平均值	
#12	H'4070	X R	CH1量測華氏溫度平均值	通道CH1 ~ CH2量測華氏溫度平均值顯示。單位0.1°F。
#13	H'4071	X R	CH2量測華氏溫度平均值	

CR#	參數位址	保持型		暫存器名稱	說明										
#14	H'4072	X	R	CH3量測華氏溫度平均值	通道CH3~ CH4量測華氏溫度平均值顯示。單位0.1°F。										
#15	H'4073	X	R	CH4量測華氏溫度平均值											
#18	H'4076	X	R	CH1量測攝氏溫度現在值	通道CH1 ~ CH4量測攝氏溫度現在值顯示。單位0.1°C。										
#19	H'4077	X	R	CH2量測攝氏溫度現在值											
#20	H'4078	X	R	CH3量測攝氏溫度現在值											
#21	H'4079	X	R	CH4量測攝氏溫度現在值											
#24	H'407C	X	R	CH1量測華氏溫度現在值	通道CH1 ~ CH4量測華氏溫度現在值顯示。單位0.1°F。										
#25	H'407D	X	R	CH2量測華氏溫度現在值											
#26	H'407E	X	R	CH3量測華氏溫度現在值											
#27	H'407F	X	R	CH4量測華氏溫度現在值											
#29	H'4081	X	R/W	PID模式設定	設定H'5678進入PID模式，其他設定值皆為一般模式。出廠設定值H'0000。										
#30	H'4082	X	R	錯誤狀態	儲存所有錯誤狀態的資料暫存器，詳細內容請參照錯誤信息表。										
#31	H'4083	O	R/W	通訊位址設定	設定RS-485通訊位址，設定範圍01 ~ 254。出廠設定值為K1。										
#32	H'4084	O	R/W	通訊速率 (Baud rate) 設定	<p>包含ASCII/RTU模式，ASCII 模式資料格式為 7 bits、偶位元、1 stop bit (7, E, 1)；RTU 模式資料格式為 8 bits、偶位元、1 stop bit (8, E, 1)。</p> <p>通訊速率設定共有六種：</p> <p>b0：4,800 bps b1：9,600 bps (出廠設定值) b2：19,200 bps b3：38,400 bps b4：57,600 bps b5：115,200 bps b6 ~ b13：保留 b14：CRC檢查碼高低位交換 (僅RTU模式有效) b15：ASCII/RTU模式切換</p>										
#33	H'4085	O	R/W	恢復出廠設定	<table border="1"> <thead> <tr> <th>b15~b12</th> <th>b11~ b9</th> <th>b8~b6</th> <th>b5~b3</th> <th>b2~b0</th> </tr> </thead> <tbody> <tr> <td>ERR燈</td> <td>CH4</td> <td>CH3</td> <td>CH2</td> <td>CH1</td> </tr> </tbody> </table> <p>以CH1設定來說明：</p> <ol style="list-style-type: none"> b0 ~ b1 保留。 b2 設定為1時，所有設定值將回復原廠設定值。 <p>ERR燈定義：原廠設定值b12 ~ b15 = 1111</p> <ol style="list-style-type: none"> b12 對應CH1，當b12=1時，刻度超過ERR燈閃爍動作。 b13 對應CH2，當b13=1時，刻度超過ERR燈閃爍動作。 b14 對應CH3，當b14=1時，刻度超過ERR燈閃爍動作。 b15 對應CH4，當b15=1時，刻度超過ERR燈閃爍動作。 	b15~b12	b11~ b9	b8~b6	b5~b3	b2~b0	ERR燈	CH4	CH3	CH2	CH1
b15~b12	b11~ b9	b8~b6	b5~b3	b2~b0											
ERR燈	CH4	CH3	CH2	CH1											
#34	H'4086	O	R	韌體版本	16進制，顯示目前韌體版本，如1.0A則H'010A。										

CR#	參數位址	保持型	暫存器名稱	說明
#35 ~ #48			系統內部使用	
符號定義： O表示為保持型；X表示為非保持型。(利用RS-485通訊控制時支援，連接主機時不支援) R表示為可使用FROM指令讀取資料，或利用RS-485通訊讀取資料。 W表示為可使用TO指令寫入資料，或利用RS-485通訊寫入資料。				

- 功能碼 (Function)：03'H 讀出暫存器資料。06'H 寫入一個 word 資料至暫存器。10'H 寫入多筆 words 資料至暫存器。
- CR#30 錯誤狀態表：

錯誤狀態	內容值	b15 ~ b8	b7	b6	b5	b4	b3	b2	b1	b0
電源異常	K1 (H'1)	保留	0	0	0	0	0	0	0	1
接點空接	K2 (H'2)		0	0	0	0	0	0	1	0
硬體故障	K16 (H'10)		0	0	0	1	0	0	0	0
平均次數設定錯誤	K64 (H'40)		0	1	0	0	0	0	0	0
指令錯誤	K128 (H'80)		1	0	0	0	0	0	0	0
註：每個錯誤狀態由相對應之位元b0 ~ b7決定，有可能會同時產生兩個以上之錯誤狀態，0代表正常無錯誤，1代表有錯誤狀態產生。										

- DVP04PT-S 在 V3.08 以上版本，當 CR#29 設定為 H'5678 時，CR#0 ~ CR#34 可做為 PID 設定使用：

PID模式內容說明			
CR#0	機種型號	CR#17	CH4 K _P
CR#2	CH1 輸出%	CR#19	CH1 K _i
CR#3	CH2 輸出%	CR#20	CH2 K _i
CR#4	CH3 輸出%	CR#21	CH3 K _i
CR#5	CH4 輸出%	CR#22	CH4 K _i
CR#6	CH1 攝氏平均溫度	CR#24	CH1 K _D
CR#7	CH2 攝氏平均溫度	CR#25	CH2 K _D
CR#8	CH3 攝氏平均溫度	CR#26	CH3 K _D
CR#9	CH4 攝氏平均溫度	CR#27	CH4 K _D
CR#10	CH1 溫度設定	CR#28	Run/Stop & Auto turning
CR#11	CH2 溫度設定	CR#29	進入PID模式 (H'5678)
CR#12	CH3 溫度設定	CR#30	錯誤碼
CR#13	CH4 溫度設定	CR#31	CH1 取樣時間
CR#14	CH1 KP	CR#32	CH2 取樣時間
CR#15	CH2 KP	CR#33	CH3 取樣時間
CR#16	CH3 KP	CR#34	CH4 取樣時間

感谢您采用台达 DVP 系列产品。DVP04PT-S 温度测量模块可接受外部 4 点铂金属温度传感器，将之转换成 14 位的数字信号。透过 DVP-PLC SS/ SA/SX/SC/SV 主机程序以指令 FROM/TO 来读写模块内的数据，模块内具有多个 CR (Control Register) 寄存器，每个寄存器有 16 bits。电源单元与模块分离，体积小，安装容易。

- ✎ 请在使用之前，详细阅读本使用说明书。实施配线，务必关闭电源。上电时请勿接触机体端子或进行维修。输入电源切断后，一分钟之内，请勿触摸内部电路。
- ✎ 本机为开放型 (OPEN TYPE) 机壳，因此使用者使用本机时，必须将其安装于具防尘、防潮及免于电击 / 冲击意外的外壳配线箱内。另必须具备保护措施（如：特殊的工具或钥匙才可打开）防止非维护人员操作或意外冲击本体，造成危险及损坏。
- ✎ 交流输入电源不可连接于输入 / 出信号端，否则可能造成严重的损坏，因此请在上电之前再次确认电源配线。
- ✎ 本体上的接地端子 \oplus 务必正确的接地，可提高产品抗干扰能力。
- ✎ 由测温体到温调本体的配线路请用最短距离配线，为了避免干扰及诱导的影响尽可能将电源线和负载配线分开。

■ 产品外观尺寸与部位介绍

详细部位指示图与外观尺寸请参阅英文版页码1的[Figure1]，单位：mm。

1. 电源、错误及运行指示灯	6. I/O 模块定位孔	11. RS-485 通讯口
2. 机种型号	7. 铭牌	12. I/O 模块固定槽
3. DIN 轨固定扣	8. I/O 模块连接口	13. 电源输入口
4. 端子	9. I/O 模块固定扣	14. I/O 模块连接口
5. 端子配置	10. DIN 轨槽 (35mm)	

■ 输入 / 输出端子台配置

请参阅英文版页码2的端子台配置示意图。

■ 外部配线

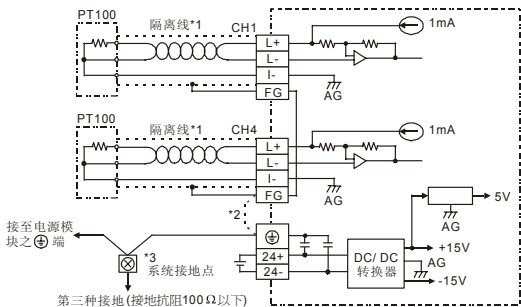

注1：用于模拟输入的配线应采用PT100温度传感器的连接线或双绞隔离线且应与其它电源线或可能引起干扰之接线分开。PT100请使用3线式温度传感器。

注2：如果干扰过大请将FG及接地端子连接。

注3：请将电源模块的 \oplus 端及DVP04PT-S温度测量模块的 \oplus 端连接到系统接地点，再将系统接地点作第三种接地或接到配电箱的机壳上。

注意：空端子请勿配线。

■ 电气规格

电源电压	24VDC (20.4VDC ~ 28.8VDC) (-15% ~ +20%)
额定最大消耗功率	2W, 由外部电源供应
操作 / 储存环境	1. 操作: 0°C ~ 55°C (温度), 50 ~ 95% (湿度), 污染等级 2 2. 储存: -25°C ~ 70°C (温度), 5 ~ 95% (湿度)
耐振动 / 冲击	国际标准规范IEC61131-2, IEC 68-2-6 (TEST Fc)/IEC61131-2 & IEC 68-2-27 (TEST Ea)
与DVP-PLC主机串接说明	模块编号以靠近主机的顺序自动编号由0到7, 最大可连接8台且不占用数字I/O点数。

■ 功能规格

DVP04PT-S	摄氏 (°C)	华氏 (°F)
模拟讯号输入通道	4通道 / 台	
适合感应器形式	3线 PT 100Ω 3850 PPM/°C (DIN 43760 JIS C1604-1989)	
驱动电流	1mA	
输入温度范围	-200°C ~ 600°C	-328°F ~ 1112°F
数字转换范围	K-2,000 ~ K6,000	K-3,280 ~ K11,120
分辨率	14 bits (0.1°C)	14 bits (0.1°F)
总和精密度	±0.5% 在 (25°C, 77°F) 范围内满刻度时。 ±1% 在 (0 ~ 55°C, 32 ~ 131°F) 范围内满刻度时。	
响应时间	200ms × 通道数	
隔离方式	数字电路与模拟电路有隔离, 通道间未隔离。 数字电路与接地之间: 500VDC 模拟电路与接地之间: 500VDC 模拟电路与数字电路之间: 500VDC 24VDC与接地之间: 500VDC	
数字数据格式	16位二补码	
平均功能	有 (CR#2 ~ CR#5)	
自我诊断功能	上下极限侦测/通道	
通讯模式 (RS-485)	有(CR#32)。当与PLC主机串接时, RS-485通讯无法使用。	

■ 控制寄存器 (CR)

CR#	参数地址	保持型	寄存器名称	说明
#0	H'4064	O R	机种型号	系统内定, DVP04PT-S机种编码= H'8A。
#2	H'4066	O R/W	CH1平均次数	通道CH1 ~ CH4信号的平均次数设定: V3.04以前版本: 可设定范围K1 ~ K4,095。 V3.05以后版本: 可设定范围K1 ~ K20。 出厂默认值为K10。
#3	H'4067	O R/W	CH2平均次数	
#4	H'4068	O R/W	CH3平均次数	
#5	H'4069	O R/W	CH4平均次数	
#6	H'406A	X R	CH1测量摄氏温度平均值	通道CH1 ~ CH4测量摄氏温度平均值显示。单位0.1°C。
#7	H'406B	X R	CH2测量摄氏温度平均值	
#8	H'406C	X R	CH3测量摄氏温度平均值	
#9	H'406D	X R	CH4测量摄氏温度平均值	
#12	H'4070	X R	CH1测量华氏温度平均值	通道CH1 ~ CH2测量华氏温度平均值显示。单位0.1°F。
#13	H'4071	X R	CH2测量华氏温度平均值	

CR#	参数地址	保持型		寄存器名称	说明										
#14	H'4072	X	R	CH3测量华氏温度平均值	通道CH3 ~ CH4测量华氏温度平均值显示。单位0.1°F。										
#15	H'4073	X	R	CH4测量华氏温度平均值											
#18	H'4076	X	R	CH1测量摄氏温度现在值	通道CH1 ~ CH4测量摄氏温度现在值显示。单位0.1°C。										
#19	H'4077	X	R	CH2测量摄氏温度现在值											
#20	H'4078	X	R	CH3测量摄氏温度现在值											
#21	H'4079	X	R	CH4测量摄氏温度现在值											
#24	H'407C	X	R	CH1测量华氏温度现在值	通道CH1 ~ CH4测量华氏温度现在值显示。单位0.1°F。										
#25	H'407D	X	R	CH2测量华氏温度现在值											
#26	H'407E	X	R	CH3测量华氏温度现在值											
#27	H'407F	X	R	CH4测量华氏温度现在值											
#29	H'4081	X	R/W	PID模式设定	设定H'5678进入PID模式，其它设定值皆为一般模式。出厂默认值H'0000。										
#30	H'4082	X	R	错误状态	储存所有错误状态的数据寄存器，详细内容请参照错误信息表。										
#31	H'4083	O	R/W	通讯地址设定	设定RS-485通讯地址，设定范围01 ~ 254。出厂默认值为K1。										
#32	H'4084	O	R/W	通讯速率 (Baud rate) 设定	<p>包含ASCII/RTU模式，ASCII模式数据格式固定为7 bits、偶位、1 stop bit (7, E, 1)，RTU模式数据格式固定为8 bits、偶位、1 stop bit (8, E, 1)。</p> <p>通讯速率设定共有六种：</p> <p>b0: 4,800 bps b1: 9,600 bps (出厂设定值) b2: 19,200 bps b3: 38,400 bps b4: 57,600 bps b5: 115,200 bps b6 ~ b13: 保留 b14: CRC检查码高低位交换 (仅RTU模式有效) b15: ASCII/RTU模式切换</p>										
#33	H'4085	O	R/W	恢复出厂设定	<table border="1"> <tr> <td>b15~b12</td> <td>b11~ b9</td> <td>b8~b6</td> <td>b5~b3</td> <td>b2~b0</td> </tr> <tr> <td>ERR灯</td> <td>CH4</td> <td>CH3</td> <td>CH2</td> <td>CH1</td> </tr> </table> <p>以CH1设定来说明：</p> <ol style="list-style-type: none"> b0 ~ b1保留。 b2设定为1时，所有设定值将回复原厂默认值。 <p>ERR灯定义：原厂设定值b12 ~ b15 = 1111</p> <ol style="list-style-type: none"> b12对应CH1，当b12=1时，刻度超过ERR灯闪烁动作。 b13对应CH2，当b13=1时，刻度超过ERR灯闪烁动作。 b14对应CH3，当b14=1时，刻度超过ERR灯闪烁动作。 b15对应CH4，当b15=1时，刻度超过ERR灯闪烁动作。 	b15~b12	b11~ b9	b8~b6	b5~b3	b2~b0	ERR灯	CH4	CH3	CH2	CH1
b15~b12	b11~ b9	b8~b6	b5~b3	b2~b0											
ERR灯	CH4	CH3	CH2	CH1											
#34	H'4086	O	R	韧体版本	16进制，显示目前韧体版本，如1.0A则H'010A。										

CR#	参数地址	保持型	寄存器名称	说明
#35 ~ #48			系统内部使用	
符号定义： O表示为保持型；X表示为非保持型。(利用RS-485通讯控制时支持，连接主机时不支持) R表示为可使用FROM指令读取数据，或利用RS-485通讯读取数据。 W表示为可使用TO指令写入数据，或利用RS-485通讯写入数据。				

- 功能码 (Function) : 03'H 读出寄存器数据。06'H 写入一个 word 数据至寄存器。10'H 写入多笔 words 数据至寄存器。
- CR#30 错误状态表：

错误状态	内容值	b15 ~ b8	b7	b6	b5	b4	b3	b2	b1	b0
电源异常	K1 (H'1)	保留	0	0	0	0	0	0	0	1
接点空接	K2 (H'2)		0	0	0	0	0	0	1	0
硬件故障	K16 (H'10)		0	0	0	1	0	0	0	0
平均次数设定错误	K64 (H'40)		0	1	0	0	0	0	0	0
指令错误	K128 (H'80)		1	0	0	0	0	0	0	0
注：每个错误状态由相对应的位b0 ~ b7决定，有可能会同时产生两个以上的错误状态，0代表正常无错误，1代表有错误状态产生。										

- DVP04PT-S 在 V3.08 以上版本，当 CR#29 设定为 H'5678 时，CR#0 ~ CR#34 可做为 PID 设定使用：

PID模式内容说明			
CR#0	机种型号	CR#9	CH4 摄氏平均温度
CR#2	CH1 输出%	CR#10	CH1 温度设定
CR#3	CH2 输出%	CR#11	CH2 温度设定
CR#4	CH3 输出%	CR#12	CH3 温度设定
CR#5	CH4 输出%	CR#13	CH4 温度设定
CR#6	CH1 摄氏平均温度	CR#14	CH1 K _P
CR#7	CH2 摄氏平均温度	CR#15	CH2 K _P
CR#8	CH3 摄氏平均温度	CR#16	CH3 K _P
CR#17	CH4 K _P	CR#27	CH4 K _D
CR#19	CH1 K _I	CR#28	Run/Stop & Auto turning
CR#20	CH2 K _I	CR#29	进入PID模式 (H'5678)
CR#21	CH3 K _I	CR#30	错误码
CR#22	CH4 K _I	CR#31	CH1 取样时间
CR#24	CH1 K _D	CR#32	CH2 取样时间
CR#25	CH2 K _D	CR#33	CH3 取样时间
CR#26	CH3 K _D	CR#34	CH4 取样时间

Delta DVP serisi PLC'leri seçtiğiniz için teşekkürler. DVP04PT-S ünitelerine 4 adet platinyum sıcaklık sensörü bağlanabilir ve bu bağlı sıcaklık sensörlerinden gelen bilgiler 14-bit dijital sinyallere dönüştürülür. Ayrıca DVP PLC CPU'da FROM/TO komutları kullanılarak DVP04PT-S modülünün içine veri yazılabilir veya okunabilir. DVP04PT-S modülünün içinde çok adet 16-bit kontrol register (CR) vardır. Ürünün beslemesi ayrı olup küçük boyutlu ve kurulumu kolaydır.

- ✓ Lütfen ürünü kullanmadan önce bu bilgi dökümanını dikkatlice okuyunuz. Üründe enerji varken terminallere dokunmayınız.
- ✓ Bu ürün AÇIK TİP I/O modülü olduğundan dolayı toz, rutubet, elektrik şoku ve titreşimden uzak kapalı yerlere kurulumu yapılmalıdır. Tehlikeleri ve ürünün zarar görmesini engellemek için yetkili olmayan kişilerin ürüne müdahale etmesini engelleyecek önlemler alınmalıdır. (Ör: Panoya kilit konulması gibi).
- ✓ DVP04PT-S ünitesinin giriş/çıkış terminallerine AC power bağlamayınız, Aksi halde ürün zarar görebilir.
- ✓ Elektromanyetik gürültüyü engellemek için, DVP04PT-S ürününün topraklamasının doğru olduğuna emin olunuz.
- ✓ Ürüne bağlanacak sensör (RTD) kablolarını mümkün olduğunca kısa bağlayınız ve elektriksel gürültüyü önlemek için I/O kablolarını güç kablolarından uzak tutunuz.

■ Ürün Görünüşü & Ölçüler

Lütfen sayfa 1'de (Şekil 1)'ye bakınız., Birim: mm.

1. Durum indikatör (POWER, RUN ve ERROR)	8. I/O modul bağlantı portu
2. Model adı	9. I/O modul klip
3. DIN ray klip	10. DIN ray (35mm)
4. I/O terminaller	11. RS-485 haberleşme portu
5. I/O nokta indikatör	12. I/O modul klip
6. Montaj delikleri	13. DC power girişi
7. Ürün Özellik Etiketi	14. I/O modul bağlantı portu

■ I/O Terminal Yerleşimi

Lütfen İngilizce versiyonu için sayfa 1 'ye bakınız.

■ Harici Bağlantı

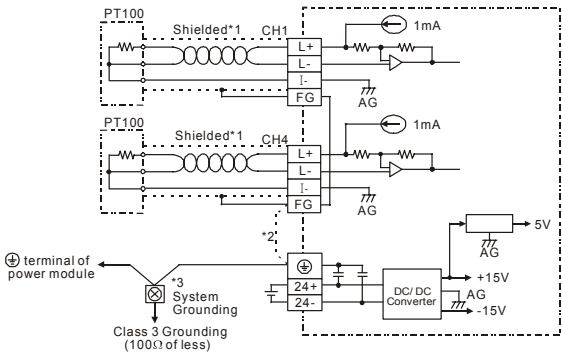

Not 1: Ürüne giriş bağlantısı yaparken sıcaklık sensörünün (PT100) orjinal kablосunu kullanınız ve bu kabloları gürültüden etkilenmemesi için güç kablolarından uzak tutunuz. PT100 bağlantısı için 3-kablo kullanınız.

Not 2: Gürültüyü önlemek için FG terminalini topraklayınız.

Not 3: Güç kaynağı modülü ⚡ terminalinden ve DVP04PT-S modülü toprak terminalinden ⚡ topraklanmalıdır.

Uyarı: No Connection (NC) terminallerine bağlantı yapmayınız.

■ Elektriksel Özellikler

Power supply voltajı	24VDC (20.4VDC ~ 28.8VDC) (-15% ~ +20%)
Max. güç tüketim oranı	2W, harici beslemeden beslenir.
Çalışma/saklama	Çalışma: 0°C~55°C (sıcaklık), 50~95% (rutubet), kirlenme derecesi 2 Saklama: -25°C~70°C (sıcaklık), 5~95% (rutubet)
Titreşim/şok direnci	Uluslararası standartlar: IEC61131-2, IEC 68-2-6 (TEST Fc)/ IEC61131-2 & IEC 68-2-27 (TEST Ea)
DVP-PLC MPU'ya seri bağlantı	Modül CPU'ya bağlandığında uzaklığına göre sırasıyla otomatik olarak 0 – 7 arası numaralandırılır. En yakın modülün numarası "0" ve en uzaktaki modülün numarası "7" dir. Maksimum 8 adet özel modül bağlanabilir ve digital I/O işgal etmezler.

■ Fonksiyonel Özellikler

DVP04PT-S	Celsius (°C)	Fahrenheit (°F)
Analog giriş kanalı	Herbir modül için 4 kanal	
Sensors tipi	3- WIRE PT 100Ω 3850 PPM/°C (DIN 43760 JIS C1604-1989)	
Akım eksitasyon	1mA	
Sıcaklık giriş aralığı	-200°C ~ 600°C	-328°F ~ 1112°F
Digital dönüşüm aralığı	K-2,000 ~ K6,000	K-3,280 ~ K11,120
Çözünürlük	14 bit (0.1°C)	14 bit (0.1°F)
Genel doğruluk	±0.5% tam skala 25°C (77°F), ±1% tam skala 0 ~ 55°C (32 ~ 131°F).	
Cevap zamanı	200ms × kanal	
İzolasyon metodu	Digital ve analog devreler arasında izolasyon mevcut. Kanallar arası izolasyon yok. 500VDC Dijital devreler ve Toprak (Ground) arasında 500VDC Analog devreler ve Toprak (Ground) arasında 500VDC Analog devreler ve Dijital devreler arasında 500VDC 24VDC ve Toprak (Ground) arasında	
Digital data formatı	16-bit, 2'nin komplementi	
Ortalama fonksiyonu	Mevcut (CR#2 ~ CR#5)	
Self diagnostic fonksiyonu	Mevcut	
Haberleşme modu (RS-485)	Mevcut (CR#32). DVP04PT-S ünitesi CPU'nun yanına takıldığı zaman RS-485 pasif olur.	

■ Kontrol Register

CR#	Adres	Kayıt	Register içeriği	Açıklama	
#0	H'4064	O	R	Model adı	Sistem tarafından ayarlanır: DVP04PT model kodu = H'8A.
#2	H'4066	O	R/W	CH1 ortalama adeti	CH1 ~ CH4 kanallarındaki "ortalama" sıcaklık değerini hesaplamak için okuma sayısıdır. Ayar aralığı: V3.04 ve öncesi: K1 ~ K4,095. V3.05 ve sonrası: K1 ~ K20. Default ayarı K10.
#3	H'4067	O	R/W	CH2 ortalama adeti	
#4	H'4068	O	R/W	CH3 ortalama adeti	
#5	H'4069	O	R/W	CH4 ortalama adeti	

CR#	Adres	Kayıt		Register içeriği	Açıklama										
#6	H'406A	X	R	CH1 ortalama sıcaklık	CH1 ~ CH4 ortalama sıcaklık değeri. (Birim: 0.1°C).										
#7	H'406B	X	R	CH2 ortalama sıcaklık											
#8	H'406C	X	R	CH3 ortalama sıcaklık											
#9	H'406D	X	R	CH4 ortalama sıcaklık											
#12	H'4070	X	R	CH1 ortalama sıcaklık	CH1 ~ CH4 ortalama sıcaklık değeri. (Birim: 0.1°F).										
#13	H'4071	X	R	CH2 ortalama sıcaklık											
#14	H'4072	X	R	CH3 ortalama sıcaklık											
#15	H'4073	X	R	CH4 ortalama sıcaklık											
#18	H'4076	X	R	CH1 mevcut sıcaklık	CH1 ~ CH2 mevcut sıcaklık değeri. (Birim: 0.1°C).										
#19	H'4077	X	R	CH2 mevcut sıcaklık											
#20	H'4078	X	R	CH3 mevcut sıcaklık	CH3 ~ CH4 mevcut sıcaklık değeri. (Birim: 0.1°C).										
#21	H'4079	X	R	CH4 mevcut sıcaklık											
#24	H'407C	X	R	CH1 mevcut sıcaklık	CH1 ~ CH4 mevcut sıcaklık değeri. (Birim: 0.1°F).										
#25	H'407D	X	R	CH2 mevcut sıcaklık											
#26	H'407E	X	R	CH3 mevcut sıcaklık											
#27	H'407F	X	R	CH4 mevcut sıcaklık											
#29	H'4081	X	R/W	PID mod ayarı	PID modu aktif etmek için H'5678 ayarlayın. Diğer ayarlar geçersizdir. Default: H'0000.										
#30	H'4082	X	R	Error (Hata) durumu	Hata kodu data register içine kaydedilir. Lütfen hata kodu tablosuna bakınız.										
#31	H'4083	O	R/W	Haberleşme adresi ayarı	RS-485 haberleşme adresi. Ayar aralığı : 01 ~ 254 ve default : K1.										
#32	H'4084	O	R/W	Haberleşme hızı (baud rate) ayarı	Haberleşme baud rate (4,800, 9,600, 19,200, 38,400, 57,600 ve 115,200bps).										
#32	H'4084	O	R/W	Haberleşme hızı (baud rate) ayarı	ASCII mod için, data formatı 7 bit, even, 1 stop bit (7, E, 1), RTU modda iken, data formatı 8 bit, even, 1 stop bit (8, E, 1). b0: 4,800 bps (bit/sn). b1: 9,600 bps (bit/sn). (default ayarı) b2: 19,200 bps (bit/sn). b3: 38,400 bps (bit/sn). b4: 57600 bps (bit/sn). b5: 115,200 bps (bit/sn). b6 ~ b13: Reserve. b14: CRC code düşük bit ve yüksek bit arasında anahtarlama (Sadece RTU modda). b15: RTU mod.										
#33	H'4085	O	R/W	Fabrika Ayarlarına Reset	<table border="1"> <tr> <td>b15~b12</td> <td>b11~ b9</td> <td>b8~b6</td> <td>b5~b3</td> <td>b2~b0</td> </tr> <tr> <td>ERR LED</td> <td>CH4</td> <td>CH3</td> <td>CH2</td> <td>CH1</td> </tr> </table> <p>Örnek: CH1 ayarı</p> <ol style="list-style-type: none"> b0 ~ b1: Reserve. b2: 1 yapılır ve ürün fabrika ayarlarına resetlenir. <p>ERR LED açıklaması: b12~b15=1111 (default ayarlar)</p> <ol style="list-style-type: none"> b12 CH1 kanalı : b12=1 ise okunan değer sınırı aştı, ERR LED flash yapar. b13 CH2 kanalı : b13=1 ise okunan değer sınırı aştı, ERR LED flash yapar. b14 CH3 kanalı : b14=1 ise okunan değer sınırı aştı, ERR LED flash yapar. b15 CH4 kanalı : b15=1 ise okunan değer sınırı aştı, ERR LED flash yapar. 	b15~b12	b11~ b9	b8~b6	b5~b3	b2~b0	ERR LED	CH4	CH3	CH2	CH1
b15~b12	b11~ b9	b8~b6	b5~b3	b2~b0											
ERR LED	CH4	CH3	CH2	CH1											

CR#	Adres	Kayıt		Register içeriği	Açıklama
#34	H'4086	O	R	Software versiyon	Yazılım versiyonunu heksadesimal olarak gösterir. Ör: H'010A = versiyon 1.0A
#35 ~ #48		Sistem kullanır			
Semboller: O: kalıcı. X: kalıcı değil. (RS-485 haberleşme kullanılırken destekler, CPU'nun yanına takıldığı zaman desteklemez) R: FROM komutu veya RS-485 kullanılarak okunabilen data. W: FROM komutu veya RS-485 kullanılarak yazılabilen data.					

- Fonksiyon kodu: 03'H – registerden data okuma. 06'H – registre 1 word yazma. 10'H – registerlere çoklu word yazma.
- CR#30 hata kodu (error code) register. Aşağıdaki tabloyu inceleyiniz:

Hata açıklaması	İçerik	b15 ~ b8	b7	b6	b5	b4	b3	b2	b1	b0
Power beslemesi anormal	K1 (H'1)	Reserve	0	0	0	0	0	0	0	1
Boş harici kontak bağlantısı	K2 (H'2)		0	0	0	0	0	0	1	0
Donanım hatası	K16 (H'10)		0	0	0	1	0	0	0	0
Ortalama adet ayarı hatası	K64 (H'40)		0	1	0	0	0	0	0	0
Komut hatası	K128 (H'80)		1	0	0	0	0	0	0	0

Not: Her hata kodu bir bite karşılık gelecektir (b0 ~ b7). İki veya daha fazla hata aynı anda meydana gelebilir. "0" normal durumu "1" ise hata olduğunu gösterir.

- CR#29 değeri H'5678 ayarlandığı zaman, DVP04PT-S V3.08 ve üzeri versiyonlarda CR#0 ~ CR#34 kontrol registerleri PID ayarları için kullanılabilir.

PID Mod İçeriği Açıklaması			
CR#0	Model adı	CR#17	CH4 K _p
CR#2	CH1 Çıkış %'si	CR#19	CH1 K _i
CR#3	CH2 Çıkış %'si	CR#20	CH2 K _i
CR#4	CH3 Çıkış %'si	CR#21	CH3 K _i
CR#5	CH4 Çıkış %'si	CR#22	CH4 K _i
CR#6	CH1 ortalama sıcaklık (°C)	CR#24	CH1 K _D
CR#7	CH2 ortalama sıcaklık (°C)	CR#25	CH2 K _D
CR#8	CH3 ortalama sıcaklık (°C)	CR#26	CH3 K _D
CR#9	CH4 ortalama sıcaklık (°C)	CR#27	CH4 K _D
CR#10	CH1 sıcaklık ayarı	CR#28	Run/Stop & Auto turning
CR#11	CH2 sıcaklık ayarı	CR#29	Enter PID mode(H'5678)
CR#12	CH3 sıcaklık ayarı	CR#30	Hata (Error) Kodu
CR#13	CH4 sıcaklık ayarı	CR#31	CH1 Örnekleme zamanı
CR#14	CH1 K _p	CR#32	CH2 Örnekleme zamanı
CR#15	CH2 K _p	CR#33	CH3 Örnekleme zamanı
CR#16	CH3 K _p	CR#34	CH4 Örnekleme zamanı